

November 12, 2021

RE: CLIENT INFORMATION SUMMARY FOR ASCENTRUST, LLC.

In accordance with Articles two (2) through five (5) of the Due Diligence Convention and the Federal Banking Commission Circular of December 1998, concerning the prevention of money laundering, and article 305 of the Swiss Criminal Code, the following information may be supplied to banks and/or other financial institutions for the purpose of verification of identity and activities of the Principal, and the nature and origin of the funds that are to be utilized. All parties have an obligation for professional discretion and to take all appropriate precautions to protect the confidentiality of the information each holds in respect of the others' activities. This legal obligation shall remain in full force and effect at all times.

Name of Corporation: AscenTrust, LLC.

1. **AscenTrust**, LLC. is a Texas Limited Liability Company whose articles of incorporation were filled on September 28, 2009 with the Secretary of State of Texas (A copy of the articles of incorporation are attached as **Appendix A**).
2. **AscenTrust** acquired an EIN (Employer Identification Number) on October 25, 2009. (A copy of the Application form, including the EIN number is attached as **Appendix B**). **Our EIN** number is **80-0611628**.
3. **AscenTrust, LLC**. is an Architect-Engineering firm, with extensive background in Business Development, Project Financing, Project Design, Project Engineering, Project Management, Procurement and Construction Management. The Company also provides sophisticated solution to complex commercial and industrial projects. (A copy of our Qualifying Document which was originally created for the Haitian Project is attached as **Appendix C**).
4. **AscenTrust** is domiciled at:
Corporate: 16920 Kuykendahl, Suite 200
Houston, Texas 77068
5. **AscenTrust** has several websites but our main one is at: <http://ascentrust.com>
6. Contact Telephone No.: 936-827-9944
7. Contact e-mail: joseph@ascentrust.com
8. Occupation: EPC and FEED Engineering
9. **AscenTrust** for the purpose of this transaction will be represented by its President and Senior Engineer: Joseph David Clement Fournier. (A copy of the Senior Engineer's resume is attached as **Appendix D**).
 - a. Full name: Joseph David Clement Fournier
 - b. Nationality: CANADIAN (A copy of the Senior Engineer's passport is attached as **Appendix E**)
 - c) Passport Number: HP966066

- d) Date of Issue: April 17, 2017
- e) Date of Expiration: April 17, 2027
- f) Date of Birth: JAN 1, 1948
- g) Place of Birth: ALBERTA, CANADA
- h) home address:

100 Hollow Tree Ln.
Suite #2006
Houston, Texas 77090

10. Banking information for AscenTrust:

Bank: JPMorgan CHASE (Chase Private Client Account)

- a) Address: 616 FM 1960 West, Suite 100, Houston, Texas 77090
- b) Account Name: ASCENTRUST LLC
- c) Account No.: 238952795
- d) Routing Number (ABA): 111000614
- e) SWIFT CODE: CHASUS33
- d) Acct. Signatory Name: Joseph Fournier
- e) Account Manager: Aracely C. Serna
- f) Account Manager Telephone: 281-587-3103

AFFIRMATION: I hereby swear under the full penalty of perjury, that the information provided herein is both true and accurate. I am in control of the ACCOUNT stated above, and have signatory authority on the aforementioned bank account and have full authority to execute all contracts and agreements.

Respectfully,

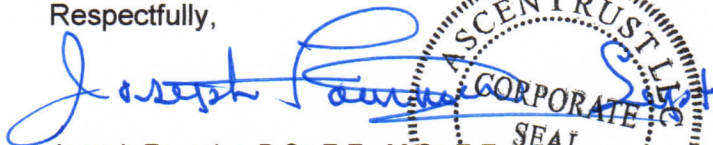

30/2021

Joseph Fournier, B.Sc.E.E., M.Sc.E.E.
President
AscenTrust, LLC.



16920 Kuykendahl
Suite 200
Houston, TX 77068
Main: 936.827.9944
www.AscenTrustLLC.com



APPENDIX A
ARTICLES OF INCORPORATION
FOR
ASCENTRUST LLC

Form 205
(Revised 01/06)

Return in duplicate to:
Secretary of State
P.O. Box 13697
Austin, TX 78711-3697
512 463-5555
FAX: 512 463-5709
Filing Fee: \$300



Certificate of Formation
Limited Liability Company

This space reserved for office use.

FILED
In the Office of the
Secretary of State of Texas
SEP 28 2009
Corporations Section

Article 1 – Entity Name and Type

The filing entity being formed is a limited liability company. The name of the entity is:

AscenTrust LLC.

The name must contain the words "limited liability company," "limited company," or an abbreviation of one of these phrases.

Article 2 – Registered Agent and Registered Office

(Select and complete either A or B and complete C)

A. The initial registered agent is an organization (cannot be entity named above) by the name of:

OR

B. The initial registered agent is an individual resident of the state whose name is set forth below:

Joseph	D.	Fournier	
First Name	M.I.	Last Name	Suffix

C. The business address of the registered agent and the registered office address is:

12818 Highway 105 West Suite 2D	Conroe	TX	77304
Street Address	City	State	Zip Code

Article 3—Governing Authority

(Select and complete either A or B and provide the name and address of each governing person.)

A. The limited liability company will have managers. The name and address of each initial manager are set forth below.

B. The limited liability company will not have managers. The company will be governed by its members, and the name and address of each initial member are set forth below.

NAME OF GOVERNING PERSON (Enter the name of either an individual or an organization, but not both.)

IF INDIVIDUAL

Joseph	D.	Fournier	
First Name	M.I.	Last Name	Suffix

OR

IF ORGANIZATION

Organization Name

ADDRESS OF GOVERNING PERSON

95 April Wind South	Montgomery	Tx	U.S	77356
Street or Mailing Address	City	State	Country	Zip Code

NAME OF GOVERNING PERSON (Enter the name of either an individual or an organization, but not both.)				
IF INDIVIDUAL				
<i>First Name</i>	<i>M.I.</i>	<i>Last Name</i>	<i>Suffix</i>	
OR				
IF ORGANIZATION				
<i>Organization Name</i>				
ADDRESS OF GOVERNING PERSON				
<i>Street or Mailing Address</i>	<i>City</i>	<i>State</i>	<i>Country</i>	<i>Zip Code</i>

NAME OF GOVERNING PERSON (Enter the name of either an individual or an organization, but not both.)				
IF INDIVIDUAL				
<i>First Name</i>	<i>M.I.</i>	<i>Last Name</i>	<i>Suffix</i>	
OR				
IF ORGANIZATION				
<i>Organization Name</i>				
ADDRESS OF GOVERNING PERSON				
<i>Street or Mailing Address</i>	<i>City</i>	<i>State</i>	<i>Country</i>	<i>Zip Code</i>

Article 4 – Purpose

The purpose for which the company is formed is for the transaction of any and all lawful purposes for which a limited liability company may be organized under the Texas Business Organizations Code.

Supplemental Provisions/Information

Text Area: [The attached addendum, if any, is incorporated herein by reference.]

16920 Kuykendahl
Suite 200
Houston, TX 77068
Main: 936.827.9944
www.AscenTrustLLC.com



APPENDIX B
EMPLOYER IDENTIFICATION NUMBER (EIN)
FOR
ASCENTRUST LLC

Application for Employer Identification Number

(For use by employers, corporations, partnerships, trusts, estates, churches, government agencies, Indian tribal entities, certain individuals, and others.)

EIN

Department of the Treasury
Internal Revenue Service

▶ See separate instructions for each line. ▶ Keep a copy for your records.

80-0611628

Type or print clearly.	1 Legal name of entity (or individual) for whom the EIN is being requested Ascentrust, LLC.	
	2 Trade name of business (if different from name on line 1)	3 Executor, administrator, trustee, "care of" name Joseph David Fournier
	4a Mailing address (room, apt., suite no. and street, or P.O. box) 25301 Borough Park Drive, Suite 224	5a Street address (if different) (Do not enter a P.O. box.)
	4b City, state, and ZIP code (if foreign, see instructions) The Woodlands, Texas 77380	5b City, state, and ZIP code (if foreign, see instructions)
	6 County and state where principal business is located Montgomery County, Texas	
	7a Name of responsible party Joseph David Fournier	7b SSN, ITIN, or EIN 548-53-7655
8a Is this application for a limited liability company (LLC) (or a foreign equivalent)? <input type="checkbox"/> Yes <input checked="" type="checkbox"/> No		8b If 8a is "Yes," enter the number of LLC members ▶
8c If 8a is "Yes," was the LLC organized in the United States? <input type="checkbox"/> Yes <input type="checkbox"/> No		
9a Type of entity (check only one box). Caution. If 8a is "Yes," see the instructions for the correct box to check.		
<input type="checkbox"/> Sole proprietor (SSN) _____ <input type="checkbox"/> Estate (SSN of decedent) _____ <input type="checkbox"/> Partnership <input type="checkbox"/> Plan administrator (TIN) _____ <input checked="" type="checkbox"/> Corporation (enter form number to be filed) ▶ _____ <input type="checkbox"/> Trust (TIN of grantor) _____ <input type="checkbox"/> Personal service corporation <input type="checkbox"/> National Guard <input type="checkbox"/> State/local government <input type="checkbox"/> Church or church-controlled organization <input type="checkbox"/> Farmers' cooperative <input type="checkbox"/> Federal government/military <input type="checkbox"/> Other nonprofit organization (specify) ▶ _____ <input type="checkbox"/> REMIC <input type="checkbox"/> Indian tribal governments/enterprises <input type="checkbox"/> Other (specify) ▶ _____ Group Exemption Number (GEN) if any ▶ _____		
9b If a corporation, name the state or foreign country (if applicable) where incorporated	State Texas	Foreign country
10 Reason for applying (check only one box)		
<input checked="" type="checkbox"/> Started new business (specify type) ▶ Engineering <input type="checkbox"/> Hired employees (Check the box and see line 13.) <input type="checkbox"/> Created a trust (specify type) ▶ _____ <input type="checkbox"/> Compliance with IRS withholding regulations <input type="checkbox"/> Created a pension plan (specify type) ▶ _____ <input type="checkbox"/> Other (specify) ▶ _____		
11 Date business started or acquired (month, day, year). See instructions. To be determined		12 Closing month of accounting year December
13 Highest number of employees expected in the next 12 months (enter -0- if none). If no employees expected, skip line 14.		14 If you expect your employment tax liability to be \$1,000 or less in a full calendar year and want to file Form 944 annually instead of Forms 941 quarterly, check here. (Your employment tax liability generally will be \$1,000 or less if you expect to pay \$4,000 or less in total wages.) If you do not check this box, you must file Form 941 for every quarter. <input type="checkbox"/>
Agricultural	Household	
15 First date wages or annuities were paid (month, day, year). Note. If applicant is a withholding agent, enter date income will first be paid to nonresident alien (month, day, year) ▶		N/A
16 Check one box that best describes the principal activity of your business.		
<input type="checkbox"/> Construction <input type="checkbox"/> Rental & leasing <input type="checkbox"/> Transportation & warehousing <input type="checkbox"/> Health care & social assistance <input checked="" type="checkbox"/> Wholesale-agent/broker <input type="checkbox"/> Real estate <input type="checkbox"/> Manufacturing <input type="checkbox"/> Finance & insurance <input type="checkbox"/> Accommodation & food service <input type="checkbox"/> Wholesale-other <input type="checkbox"/> Retail <input type="checkbox"/> Other (specify) _____		
17 Indicate principal line of merchandise sold, specific construction work done, products produced, or services provided. Industrial, commercial and Residential Construction		
18 Has the applicant entity shown on line 1 ever applied for and received an EIN? <input type="checkbox"/> Yes <input checked="" type="checkbox"/> No If "Yes," write previous EIN here ▶ _____		

Third Party Designee	Complete this section only if you want to authorize the named individual to receive the entity's EIN and answer questions about the completion of this form.	
	Designee's name	Designee's telephone number (include area code) ()
	Address and ZIP code	Designee's fax number (include area code) ()

Under penalties of perjury, I declare that I have examined this application, and to the best of my knowledge and belief, it is true, correct, and complete.

Name and title (type or print clearly) ▶ Joseph David Fournier, President	Applicant's telephone number (include area code) (936) 827-9944
Signature ▶ <i>Joseph Fournier</i>	Applicant's fax number (include area code)
Date ▶ Oct 25/2009	

16920 Kuykendahl
Suite 200
Houston, TX 77068
Main: 936.827.9944
www.AscenTrustLLC.com



The POWER of ENGINEERING

APPENDIX C
PROFESSIONAL SERVICES CAPABILITIES
FOR
ASCENTRUST, LLC.

AscenTrust, LLC., (The Company) formed as a Limited Liability Company is a Joint Venture incorporated in the State of Texas in 2009, to allow the **Senior Engineer**, our **Strategic Partners** and **Consultants** to participate in the Administration and implementation of Humanitarian Grants. **The Company** provides Project Engineering, Project Design, Project Management and Construction Management for the humanitarian projects for which the **Senior Engineer** has a hand in Funding or has been assigned to the Group given the administration of a Humanitarian Grant.



Mr. Joseph Fournier B.Sc.E.E., M.Sc.E.E.
Senior Scientist and Engineer

The Company, through its senior scientist and Engineer is in possession of a large number of innovative pieces of intellectual properties concerning the production of electrical energy with wind, wave, solar, bio-mass, geo-thermal, and nuclear fission.

The Company through its Senior Engineer, its Engineering and Construction Staff, its Consulting Staff and Strategic Partners have hundreds of man-years of accumulated experience in the production of electrical energy with the use of Natural Gas. Our management strength stems from several hundred man-years of experience along every step of the **LNG** supply chain, and in the implementation of Natural Gas Power Projects.

The Company brings a strong moral and ethical code to all of its business dealings. Ethical and moral behavior is at the forefront of all its relationships and this translates into building trust and confidence both from the Funding Entities and from the client.

The Company offices in the Woodlands, north of the **City of Houston**, and its strategic partners are located all over the U.S., Canada, Africa, Asia and the Caribbean.

A professionally managed and owned enterprise with its management team possessing decades of proven track record of successfully delivering Power Project management, engineering, refurbishment, plant maintenance, O&M and turnkey solutions to clients in the US and around the world. The Company offers a “one stop shop” for project development and management, value added services, equipment supply, construction and related services in the Power Sector.

PROJECT MANAGEMENT

Over 30 years of Project Management Experience in diverse industries and multi-million dollar projects including, but not limited to:

- Power Plant Design and Construction
- Infrastructure: Water, Sewer, Fiber-Optic Cabling, Electrical Power Distribution
- Industrial, Commercial and Residential Construction Projects
- Nuclear Power Plant Development and Research (Patentable Research in fourth generation Nuclear Power Plant Design)
- Water Retention and flood control using water as a temporary levee system (Own part of this patent and working on extending the patent to absorb energy from the Tsunamis)
- Research and Development in Gas Turbine Technologies including closed cycle
- R&D in Superconducting Transmission Facilities
- Software Development (A/I Rules-based diagnostic medical Software of my own design and implementation)
- Telecommunication
- A/I Research

ENGINEERING

PROBLEM SOLVING & IMPROVING: The Engineering team comes from a high level Research and Development Background and has had remarkable success in diverse areas of Engineering. Not afraid to take on big challenges. Good grasp of technology and quickly able to extend existing technologies.

HIGHLY CREATIVE AND INNOVATIVE: The Scientific and Engineering team is always looking for ways to improve the technologies under development. Our Development team looks for practical solutions to problems. Although we tend to look at the big picture, the engineering staff of The Company understand that the devil is in the detail and our experience has taught us to pay close attention to the details.

ELECTRICAL ENGINEERING

Mr. Fournier has over 40 years of electrical engineering experience in the field of commercial and industrial plant design, construction and plant start-up. Responsibilities include conceptual engineering detail design, short circuit studies, load flow studies, coordination studies for fuse, circuit breakers and relay setting, substation design, control schematic design, PLC design and programming in addition to project management and coordination, man power forecast, project scheduling, cost estimate and specification writing.

An Electrical Engineer, with a lifetime of experience in the electrical generation field, the Senior Engineer has worked on rotating machinery for over forty years. Mr. Fournier's extensive experience includes the specification of new turbo-machinery systems, retrofit design, installation, commissioning, troubleshooting, operational optimization, and failure analysis of all types of turbo-machinery used in power generation, oil & gas, petrochemical & process plants and aviation. The land-based turbines (gas, steam or combined cycle) in question were typically made by General Electric, Alstom power, Siemens Westinghouse, Rolls Allison, Solar and the companies they formerly were, before some of them merged.

The following list indicates a few of the electrical engineering skill sets acquired by the Senior Engineer in his professional Career.

- Design of PCM equipment (First generation)
- Design of FM multiplexing equipment for T-1 lines
(First generation-Microwave repeater systems)
- Design of highly redundant systems for telemetry on oil-pipelines
- Design of a National Telephone System for the Country of Tunisia
- Design of large vertical electric motors- H.P. up to 5000hp.
- Design of high-voltage transmission facilities up to 144,000 Volts
3-phase Y and Delta Systems (underground and overhead)
- Design of underground and overhauled power feeds to minor subdivisions and shopping centers
- Load Analysis for residential, commercial and Industrial buildings
- Design of Natural gas turbine generation : up to 171MWe
- Design of Combined Cycle Power Plants, up to 650 MWe
- Design of Co-generation Power Plants: up to 100MWe
- Design of Natural gas steam turbine power plant: up to 650 MWe
- Load analysis for co-generation facilities

ATTACHMENT A: THE LNG SUPPLY CHAIN

The **Company** with its Consultants and strategic partners possesses more than one hundred man-years of experience in the Engineering, Procurement and Construction Management over the entire **LNG Supply Chain**. The whole process of LNG Development is referred to as the LNG Supply Chain and is outlined in the attached **ATTACHMENT A**.

ATTACHMENT B: POWER GENERATION CAPABILITIES OF ASCENTRUST, LLC.

AscenTrust, LLC. (The Company) is a professionally managed strategic partnership with its management team and strategic partners possessing decades of proven track record of

successfully delivering Power Project management, engineering, refurbishment, plant maintenance, O&M and turnkey solutions to clients in the US and around the world. **The Company** provides reliable and competitive services to clients, with a view to narrow the widening gap between demand and supply fueled by today's unprecedented upturn in the Electrical Power Sector.

The Company offers a "one stop shop" for project financing, project design, project engineering project development and management, value added services, equipment supply, construction and related services in the Power Sector. **The Company** has the capability to offer complete Engineering Procurement and Construction (EPC) up to and including commissioning, start-up testing and handover to the customer. Brown Energy Group also offers Operation and Maintenance services, experience within our Company totals over 40 Years in the Power Industry, The Engineering and Construction staff has been involved in many national and international projects that includes the installation of large Nuclear Power Plant and large Coal Fired Power Plants. **The Company** has personnel with extensive engineering, sales and operation experience in the various areas of expertise, such as:

- Greenfield Development
- Cogeneration Systems
- Power Purchase Agreement Negotiations
- Fuel Supply Contracts
- Environmental Permitting
- Renewable Energy
- Waste to Energy
- Steam Turbine Generating (STG) Systems.
- Heat Recovery Steam Generators (HRSG).
- Boilers for Power Generation using a wide variety of fuels.
- Bio-Mass Power Generating Systems.

The Company incorporates brand new, unused surplus, remanufactured, overhauled or used power generating equipment and related equipment including:

- Industrial Combustion Turbine Generating Units (GTG) using Natural Gas and/or Diesel fuel in Simple or Combined Cycle.
- Aero-derivative Combustion Turbine Generating Units using Natural Gas and/or Diesel fuel in Simple Cycle or Sprint configurations.

- Steam Turbine Generating (STG) Systems
- Heat Recovery Steam Generators (HRSG)
- Boilers for Power Generation using a wide variety of fuels
- Waste-to-Energy Systems
- Bio-Mass Power Generating Systems
- Cogeneration Systems
- Medium Speed Reciprocating Engine Generating Units fueled by Diesel No. 2, Heavy Fuel Oil (HFO) or Natural Gas.
- High Speed Reciprocating Engine Generating Sets fueled by Diesel No. 2, Natural Gas or Dual Fueled (Natural Gas with Diesel No. 2 as pilot fuel).
- Mini-refineries to process crude oil to a combustible mix of fuels suitable for gas turbines or gas engines and a residual mix suitable for asphalt use for use in road building.
- Wind Power Systems
- Solar Thermal and Solar Photovoltaic Power Generating Systems
- Hydroelectric Power Systems
- Geothermal Power Systems
- Bio – fuel Production Systems

ATTACHMENT C: THE FABRICATION CAPABILITIES OF ASCENTRUST, LLC.

AscenTrust, LLC., with it's strategic partners operates two different fabrication facilities, one of these facilities is located in Conroe and the other is located near the ship channel in Houston, Texas. **Diamond Fab** is our custom fabricating facility located in Conroe, Texas providing a wide variety of services which include pipe fabrication, structural fabrication and galvanizing. The management of Diamond Fabrication, with a combined total of over forty years in the welding and fabricating industry, understand the importance of quality performance and on time delivery at competitive prices. Our fabrication operation is fully capable of providing necessary services to facilitate rapid turnaround for all projects undertaken by any of our strategic partners.

Complete Turnkey Fabrication

- Material Procurement
- Weld Fabrication
- Coating Services
- Shipping

PROJECT MANAGEMENT CAPABILITIES

Some of the projects completed by the Senior Engineer over the years in the Montgomery County area of Texas can be found in Appendix D.

AscenTrust, LLC. (The Company) was originally formed to administer the front end of the Nuclear Prototype development and therefore consists of literally hundreds of individuals with very impressive resumes. The resumes of these individual can be found in the Appendix to the attached **Private Placement Memorandum for the Bay City Nuclear Project**. The Senior Engineer and the following individuals will form the Command and Control core of the Infrastructure development capabilities of **AscenTrust, LLC**.

- Joseph Fournier B.Sc.E.E., M.Sc.E.E.
- Dr. Gary Sorenson, Phd.
- William Begley
- Tom Young
- Larry Deckerhoff
- Jeff Long
- Jeff Martin
- Mark Bates
- Michael Kramer
- Tom Donaldson
- Tom Cook
- Daren Selnick



16920 Kuykendahl
Suite 200
Houston, TX 77068
Main: 936.827.9944
www.AscenTrustLLC.com



The POWER of ENGINEERING

**APPENDIX C
ATTACHMENT A
ASCENTRUST, LLC.
PROFESSIONAL SERVICES CAPABILITIES
FOR
DESIGN AND CONSTRUCTION
OF LIQUID NATURAL-GAS
SUPPLY CHAIN**

LNG Supply Chain

The **Company** with its Consultants and strategic partners possesses more than one hundred man-years of experience in the Engineering, Procurement and Construction Management over the entire **LNG Supply Chain**. The whole process of LNG Development is referred to as the LNG Supply Chain and consists of field development, liquefaction, shipping and receiving terminal and is illustrated in the Drawing below.

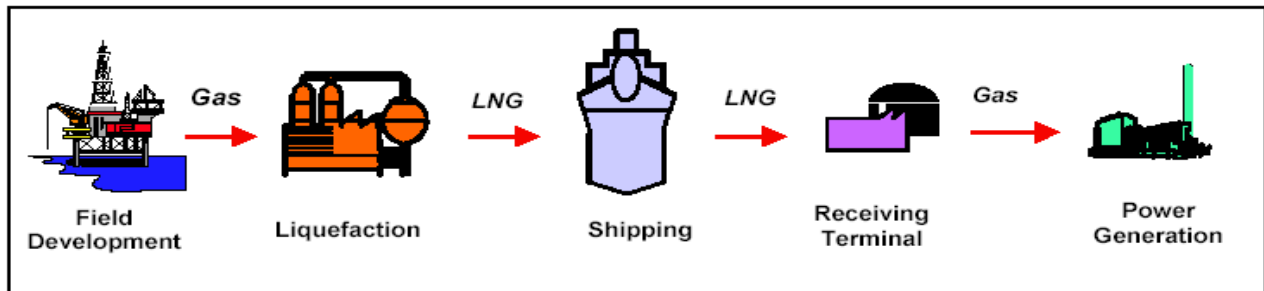

LNG Field Development:

Natural gas accounts for about one quarter of all energy consumed in the United States. Approximately 14 percent of U.S. natural gas consumption is for electricity generation. Natural gas also serves as the raw material to make paint, plastics, fertilizer, steel, fabrics, glass and numerous other products. Natural gas is vital to the U.S. economy.

Natural gas is commercially extracted from oil fields and natural gas fields. Gas extracted from oil wells is called casinghead gas or associated gas. The natural gas industry is extracting gas from increasingly more challenging resource types: sour gas, tight gas, shale gas and coalbed methane.

The Company, its Consultants and its strategic partners have more than 100 man-years of high level field experience in leasing potential gas properties, the geophysics, seismic, 3-D assessment, where the field development begins.

The Company, its Consultants and its strategic partners have more than 100 man-years of high level field experience in pipeline construction and natural gas gathering systems.

The Company, its Consultants and its strategic partners (mainly **Offshore Technical Services**) have more than 30 years of high level field experience in offshore platform instrumentation, piping and energy production. The main project managers of **OTSI** were acquired from **McDermott**. The Senior Engineer of **AscenTrust, LLC** was in charge of operations for **OTSI** for many years.

The Company, its Consultants and its strategic partners have a presence in the shallow water (400 Feet) gas fields off the coast of Trinidad. These fields are collecting natural gas which is being liquefied at the Point Fortin LNG Liquefaction Plant. In the first phases of operations in **Haiti** the **LNG** used in the power plants will be imported from this terminal in Trinidad.

OFFSHORE OIL AND GAS PLATFORM OPERATED BY GEORESOURCES



OFFSHORE NATURAL GAS COLLECTION PLATFORM IN TRINIDAD WATER



1.1. Liquefaction

In the early stages of the installation of generating capacity in Haiti the liquefaction and loading facility in Trinidad will be used to acquire **LNG**.

POINT FORTIN LNG LIQUIFACTION PLANT AND LOADING TERMINAL



After the initial phase of funding the Senior Engineer of the Company suggests the acquisition of the Import Terminal at **Lake Charles, Louisiana**. This facility has been closed for several years and could be bought at pennies on the dollar. This facility could easily be converted into a liquefaction and loading terminal.

TRUNKLINE LNG LAKE CHARLES TERMINAL



After the initial phase of funding the Senior Engineer of the Company also suggests the acquisition of Cheniere Energy, Inc., the owner of **Sabine Pass LNG** receiving terminal in Cameron Parish, **Louisiana**. This facility has been slated and approved by **FERC** for the installation of a **liquefaction** component. Cheniere Energy, Inc. is not doing well financially because of the U.S. glut in Natural Gas, and a buy-out or Joint-Venture would be easily arranged if we could guarantee a constant demand from the Caribbean Islands for American **LNG**. This facility could also easily be converted into a liquefaction and loading terminal.

NOTE: Cheniere Energy, Inc. (NYSE Amex Equities: LNG), a Delaware corporation, is a Houston-based energy company primarily engaged in LNG-related businesses. Cheniere owns and operate the Sabine Pass LNG receiving terminal in Louisiana through Cheniere Energy Partners, L.P. (NYSE Amex Equities: CQP), which is a publicly traded partnership.

Cheniere also owns and operates the Creole Trail Pipeline, which interconnects the Sabine Pass LNG receiving terminal with downstream markets. A subsidiary, Cheniere Marketing, LLC, is marketing LNG and natural gas and is developing a portfolio of contracts to monetize capacity at the Sabine Pass LNG receiving terminal and the Creole Trail Pipeline.

Cheniere is also in various stages of developing other LNG receiving terminal and pipeline related projects, which, among other things, will require primarily an infusion of capital or an acceptable commercial arrangements.

MAP OF PROPOSED CONNECTION OF LNG TERMINAL TO MAJOR TRUNKLINES

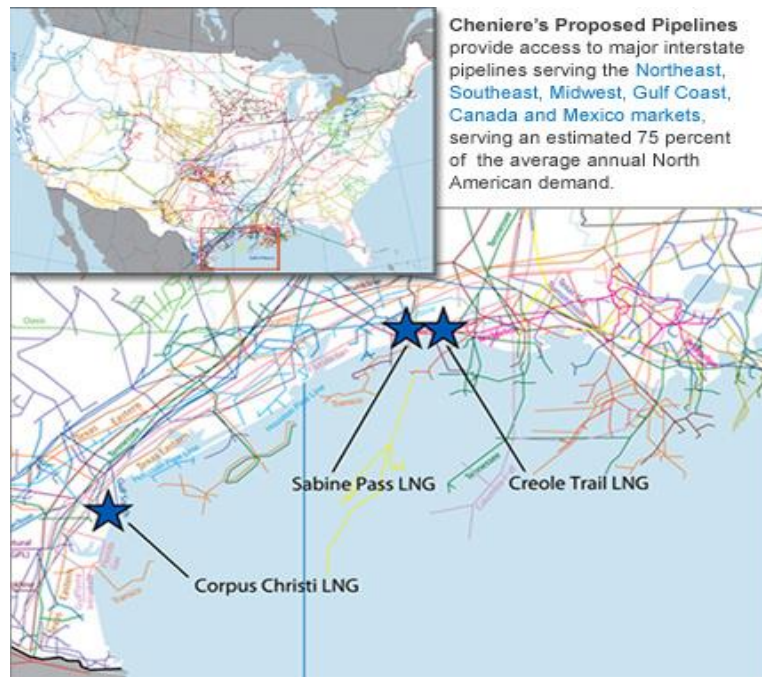

ARIAL VIEW OF SABINE PASS LNG TERMINAL



Sabine Pass LNG Terminal

Site: 853 acres
 Accessibility: 40' channel
 Proximity: 3.7 nautical miles from coast
 Berths: 2 docks
 Storage: 3 tanks (10.1 Bcf)
 Vaporization: 2.6 Bcf/d sendout
 In Service: 2008

Expansion

Storage: 3 tanks (10.1 Bcf)
 Vaporization: 1.4 Bcf/d sendout
 In Service: 2009 (2 tanks only)

NOTE: The Sabine Pass LNG terminal is located on 853 acres of land along the Sabine Pass River on the border between Texas and Louisiana, in Cameron Parish, Louisiana. It is located at the widest point on the Sabine River Navigation Channel, only 3.7 nautical miles from the open water and 23 nautical miles from the outer buoy. The channel is maintained at a depth of 40 feet and is not subject to tidal limitations. The terminal has two docks that are recessed far enough so that no part of the LNG vessel will protrude into the open waterway while docked.

Phase 1 of Sabine Pass LNG commenced service in April 2008 and by mid-2009 the first stage of the Phase 2 expansion was completed. With a total send-out capacity of 4.0 Bcf/d and 16.8 Bcf of storage capacity the Sabine Pass terminal is the largest receiving terminal, by regasification capacity, in the world. In the future stages of Phase 2 we may add a sixth storage tank and related facilities to bring the total LNG storage volume to 20.2 Bcf.

The terminal is capable of receiving and unloading approximately 400 LNG vessels each year. Each regular carrier will take approximately 10 to 12 hours to unload, with a QMax-class vessel projected to unload in approximately 18 hours. The terminal can simultaneously unload LNG vessels from each berth in order to maximize the number of LNG vessels that can be received at the terminal each year.

1.2. SHIPPING

LNG is transported in specially designed ships to re-gasification facilities. These ships are double-hulled and have capacities from 25,000 to 138,000 m³ or more. The ships are fitted with a special cargo containment system inside the inner hull to maintain the LNG at atmospheric pressure and in its liquid state. The majority of the LNG ships in the fleet are of the **Moss Design**.

NOTE: Moss Design: This design is owned by the Norwegian company Moss Maritime and it is a spherical tank. Most Moss type vessels have 4 or 5 tanks. The outside of the tank has a thick layer of foam insulation that is either fitted in panels or in more modern designs wound round the tank. Over this insulation is a thin layer of "tin foil" which allows the insulation to be kept dry with a nitrogen atmosphere.

ISOMETRIC VIEW AND DETAIL OF MOSS DESIGN LNG CARRIER

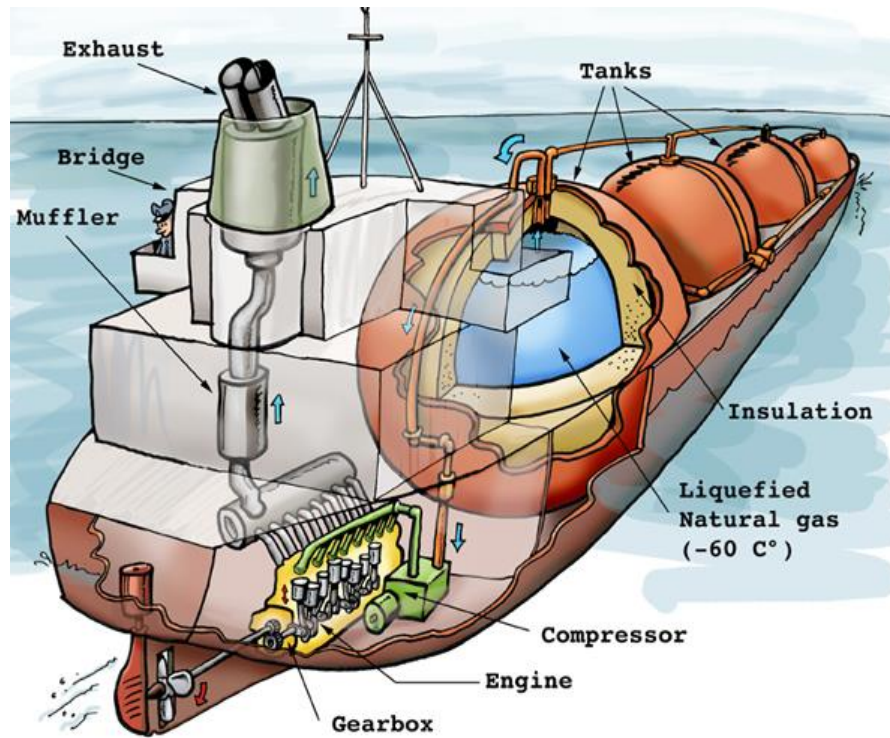

PHOTGRAPH OF A MOSS DESIGN LNG CARRIER FOR SALE



1.4. RECEIVING TERMINAL

Near the end of the supply chain is the receiving terminal. The key components of the proposed LNG terminal, including marine jetty facilities for unloading LNG, special tanks for LNG storage, process equipment for the re-gasification of LNG, utilities and other infrastructure, are depicted in the process overview in the following diagram.

PROCESS OVERVIEW OF RECEIVING TERMINAL TO BE BUILT IN HAITI

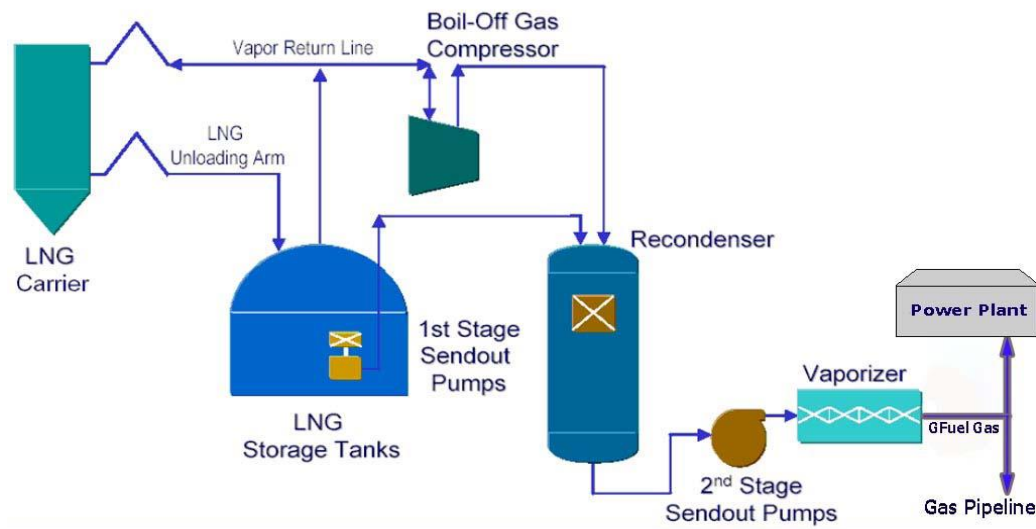

ARIAL PHOTOGRAPH OF EXISTING LNG RECEIVING TERMINAL



RENDERING OF PROPOSED LNG RECEIVING TERMINAL IN HAITI PREPARED FOR ASCENTRUST, LLC. BY LANDPLAN ENGINEERING



PROPOSED LNG RECEIVING TERMINAL IN HAITI

AscenTrust, LLC. proposes the composition of the LNG receiving terminal to contain the following components:

- Tank farm with 2 LNG tanks, 1 LPG tank and a condensate tank
- Metering stations for LPG and condensate
- Transfer station for LNG, LPG and condensate
- Construction jetty for site supply
- Construction jetty for construction activities
- Utility service station for offshore/subsea production
- Ethane and propane refrigerant drum
- Hot oil drain drum
- MEG (methylethylene glycol) tanks
- Fresh and demineralized water tanks

- High and low pressure flares with separators
- Cooling water intake and pump pit , sump, outlet and weir box
- Fire-extinguishing water system
- Effluent and sewer treatment plant
- Electrical power network, substations for tank storage and harbor
- Buildings for the central control room, offices,canteen, first aid, bathrooms, maintenance facilities,
- warehouse, fire station, garage parking lots, guard houses/check points
- on island (including fence between two areas), harbor offices, chemical storage, storage for gas bottles,
- harbor facilities for tug and mooring boats
- Permanent camp
- Temporary camp
- roads, helicopter landing area
- Rock protection walls
- Service harbor

CROSS-SECTION OF PROPOSED LNG STORAGE TANKS AT RECEIVING TERMINAL IN HAITI

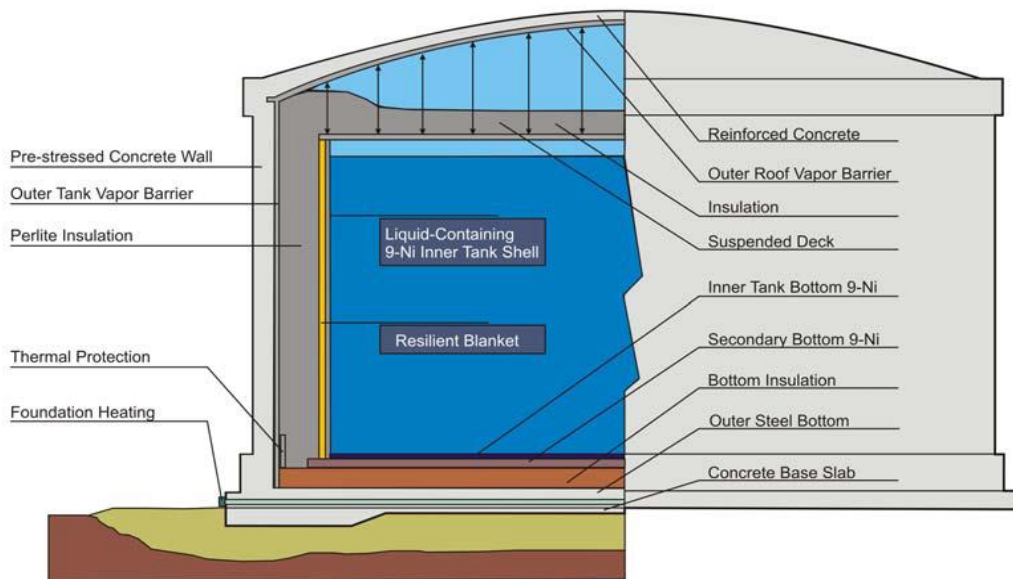

16920 Kuykendahl
Suite 200
Houston, TX 77068
Main: 936.827.9944
www.AscenTrustLLC.com



The POWER of ENGINEERING

APPENDIX C
ATTACHMENT B
POWER PRODUCTION SERVICES CAPABILITIES
FOR
DESIGN AND CONSTRUCTION
OF A NATURAL GAS FIRED, POWER PLANT

AscenTrust, LLC. (The Company) is a professionally managed strategic partnership with its management team and strategic partners possessing decades of proven track record of successfully delivering Power Project management, engineering, refurbishment, plant maintenance, O&M and turnkey solutions to clients in the US and around the world. **The Company** provides reliable and competitive services to clients, with a view to narrow the widening gap between demand and supply fueled by today's unprecedented upturn in the Electrical Power Sector.

The Company offers a "one stop shop" for project financing, project design, project engineering project development and management, value added services, equipment supply, construction and related services in the Power Sector. **The Company** has the capability to offer complete Engineering Procurement and Construction (EPC) up to and including commissioning, start-up testing and handover to the customer.

The staff has been involved in many national and international projects that includes the installation of large Coal Fired Power Plants. **The Company** has personnel with extensive engineering, sales and operation experience in the various areas of expertise, such as:

- Greenfield Development
- Build Own/Operate Transfer Projects
- Cogeneration Systems
- Engineered Solutions
- Thermal Modeling
- Financial Engineering
- Turnkey Projects
- Project Management
- Power Purchase Agreement Negotiations
- Fuel Supply Contracts
- Environmental Permitting
- Renewable Energy
- Waste to Energy
- Operation and Maintenance
- Steam Turbine Generating (STG) Systems.
- Heat Recovery Steam Generators (HRSG).
- Boilers for Power Generation using a wide variety of fuels.
- Waste-to-Energy Systems.
- Bio-Mass Power Generating Systems.

The Company incorporates brand new, unused surplus, remanufactured, overhauled or used power generating equipment and related equipment including:

- Industrial Combustion Turbine Generating Units (GTG) using Natural Gas and/or Diesel fuel in Simple or Combined Cycle.
- Aero-derivative Combustion Turbine Generating Units using Natural Gas and/or Diesel fuel in Simple Cycle or Sprint configurations.

- Steam Turbine Generating (STG) Systems
- Heat Recovery Steam Generators (HRSG)
- Boilers for Power Generation using a wide variety of fuels
- Waste-to-Energy Systems
- Bio-Mass Power Generating Systems
- Cogeneration Systems
- Medium Speed Reciprocating Engine Generating Units fueled by Diesel No. 2, Heavy Fuel Oil (HFO) or Natural Gas.
- High Speed Reciprocating Engine Generating Sets fueled by Diesel No. 2, Natural Gas or Dual Fueled (Natural Gas with Diesel No. 2 as pilot fuel).
- Mini-refineries to process crude oil to a combustible mix of fuels suitable for gas turbines or gas engines and a residual mix suitable for asphalt use for use in road building.
- Wind Power Systems
- Solar Thermal and Solar Photovoltaic Power Generating Systems
- Hydroelectric Power Systems
- Geothermal Power Systems
- Bio - fuel Production Systems

An Electrical Engineer, with a lifetime of experience in the electrical generation field, the Senior Engineer has worked on rotating machinery for over forty years. Mr. Fournier's extensive experience includes the specification of new turbo-machinery systems, retrofit design, installation, commissioning, troubleshooting, operational optimization, and failure analysis of all types of turbo-machinery used in power generation, oil & gas, petrochemical & process plants. The land-based turbines (gas, steam or combined cycle) in question were typically made by General Electric, Alstom power, Siemens Westinghouse, Rolls Allison, Solar and the companies they formerly were, before some of them merged.



NATURAL GAS FIRED POWER PLANTS

PART A: SINGLE CYCLE NATURAL GAS TURBINES

SIEMENS SGT-100 (5.25 MWe)

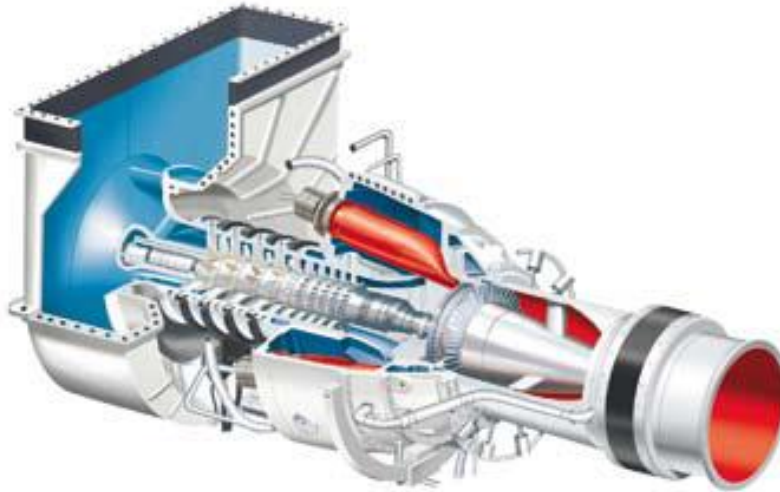

SIEMENS SGT-200 (6.75 MWe)

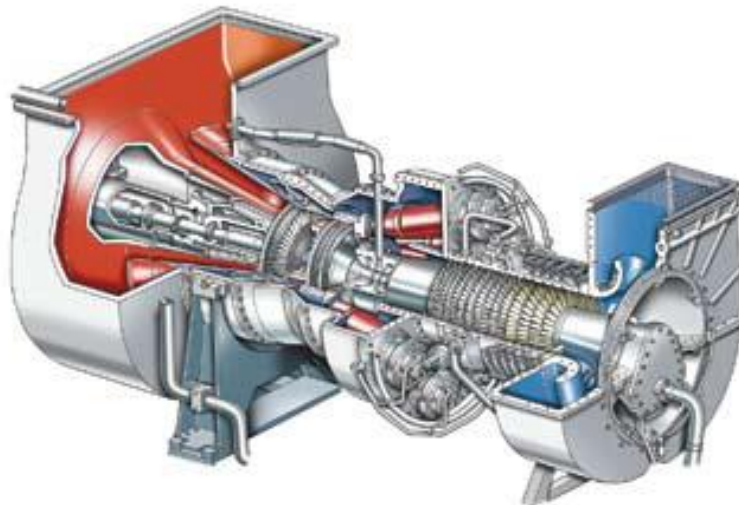

SIEMENS SGT-700 (31.21 MWe)

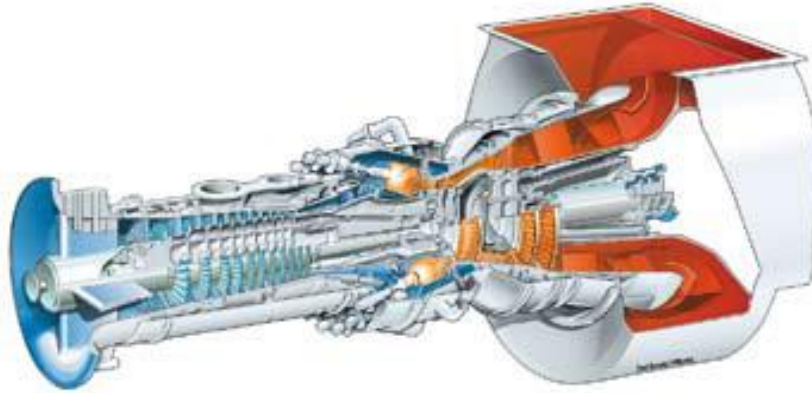

PART B: STANDARD PACKAGED UNITS

SOLAR SATURN 20 1.2MWe OIL AND GAS PACKAGE UNIT

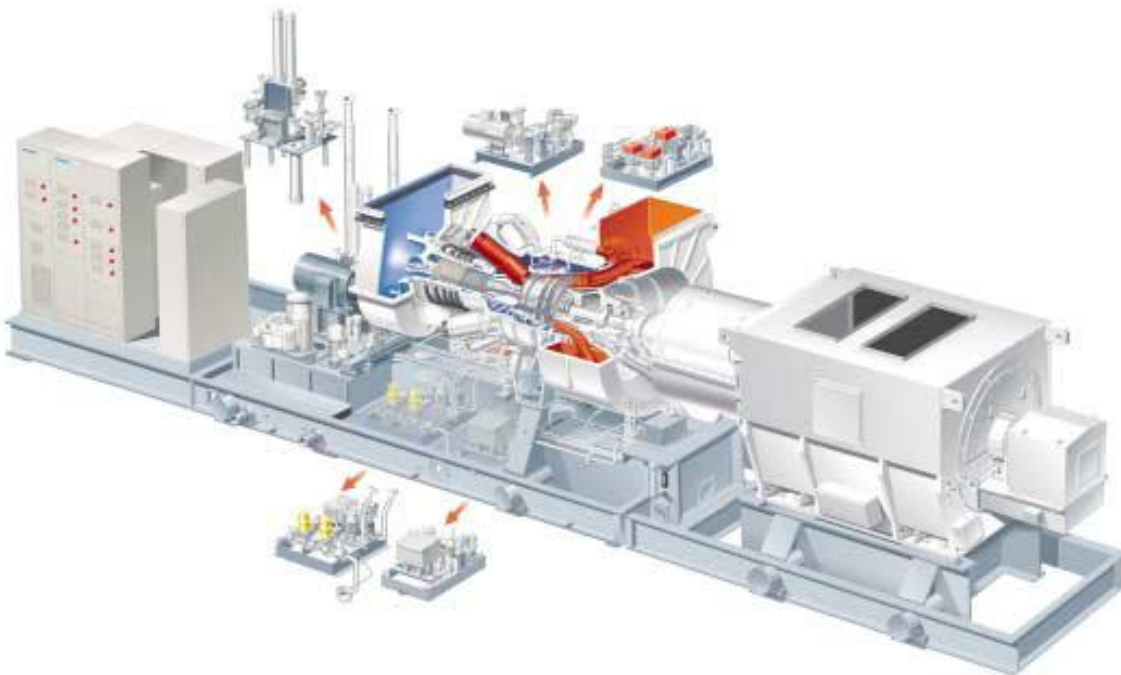

SIEMENS SGT-400 STANDARD PACKAGE

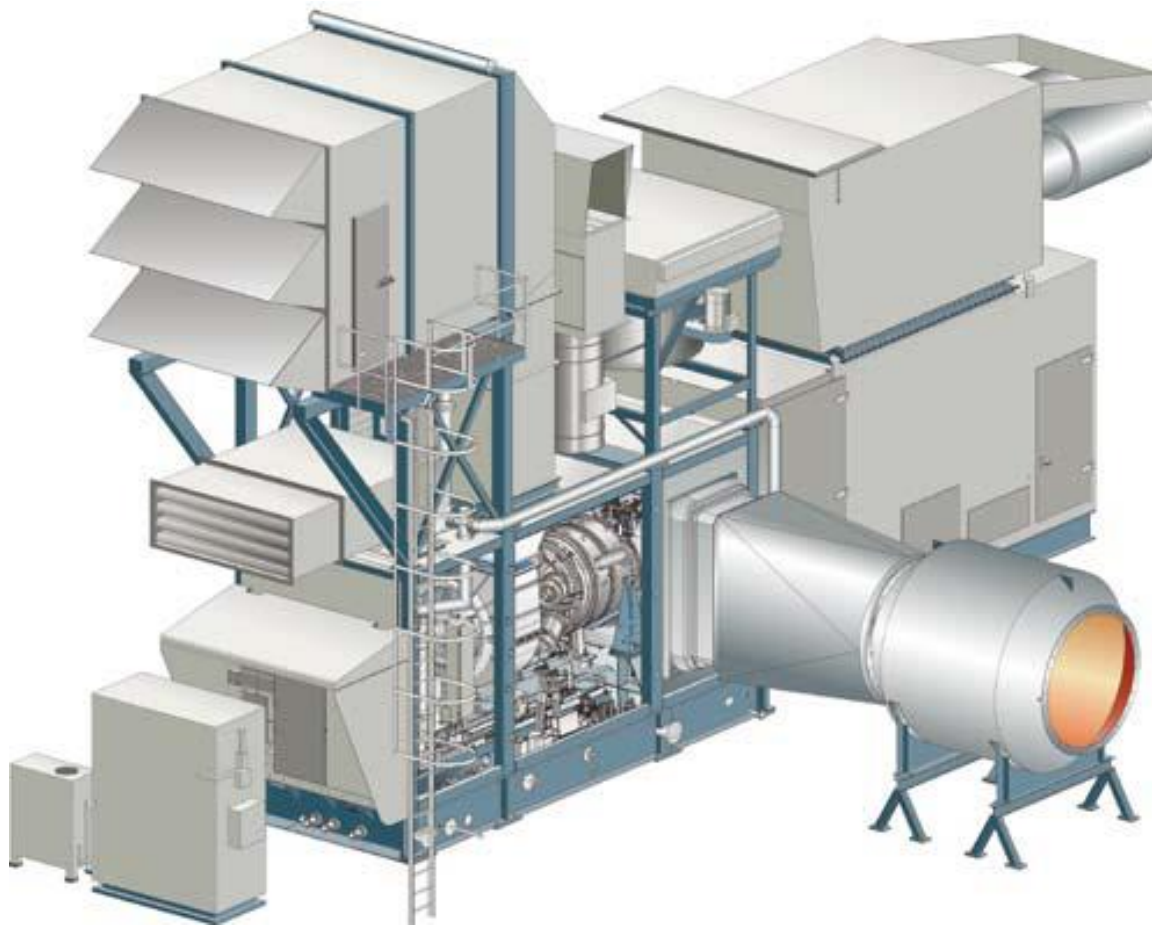

SGT-400 standard package, Power Generation: 12.90 MWe

- Lube oil cooler
- Enclosure air outlet
- Combustion air inlet
- Enclosure air inlet
- Fire and gas system
- On-package controls
- Core engine
- Combustion exhaust
- AC generator

RENDERING OF SIEMENS GAS TURBINE PACKAGES FROM 100MWe TO 340MWe

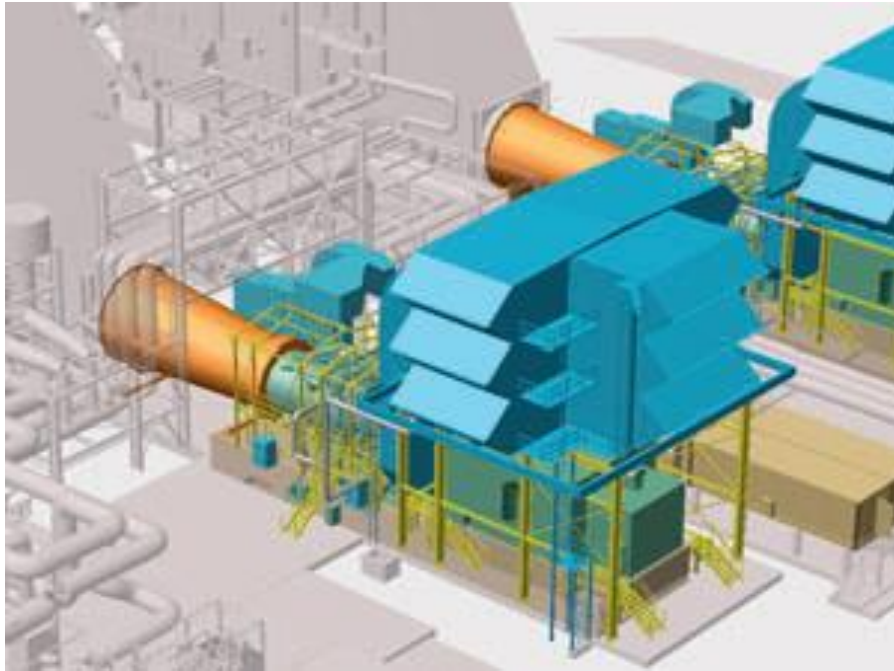

Siemens Gas Turbines common technical features:

- Four-stage turbine for moderate stage loading
- Low NOX combustion system for reduced environmental impacts
- Cold end generator drive for increased efficiency
- Two-bearing rotor for simplified rotor alignment
- Variable inlet guide vanes for improved efficiency
- All blades removable with rotor in place for easy maintenance and shorter outages

PART C: COMBINED-CYCLE POWER PLANTS

395 MWe COMBINED-CYCLE POWER PLANT



600 MWe Combined Cycle Power Plant @ Lewis Creek in Texas



16920 Kuykendahl
Suite 200
Houston, TX 77068
Main: 936.827.9944
www.AscenTrustLLC.com



The POWER of ENGINEERING

**APPENDIX C
ATTACHMENT C
FABRICATION SERVICES CAPABILITIES
FOR
ASCENTRUST, LLC.
AND
STRATEGIC PARTNERS**

FABRICATION

AscenTrust, LLC., with its strategic partners operates two different fabrication facilities, one of these facilities is located in Conroe and the other is located near the ship channel in Houston, Texas. **Diamond Fab** is our custom fabricating facility located in Conroe, Texas providing a wide variety of services which include pipe fabrication, structural fabrication and galvanizing. The management of Diamond Fabrication, with a combined total of over forty years in the welding and fabricating industry, understand the importance of quality performance and on time delivery at competitive prices. Our fabrication operation is fully capable of providing necessary services to facilitate rapid turnaround for all projects undertaken by any of our strategic partners.

Complete Turnkey Fabrication

- Material Procurement
- Weld Fabrication
- Coating Services
- Shipping

40,000 SQ. FT. FABRICATION SHOP IN CONROE



LARGE DIAMETER PIPE FABRICATION



LARGE DIAMETER MECHANICAL SHOP PIPE WELDING



ASME PRESSURE VESSEL FABRICATION



SHELL AND TUBE HEAT EXCHANGERS FABRICATION AND INSTALATION



**VALVE SKIDS AND SUPPORT MEMBERS
INCLUDING SHIPPING AND INSTALLATION.**

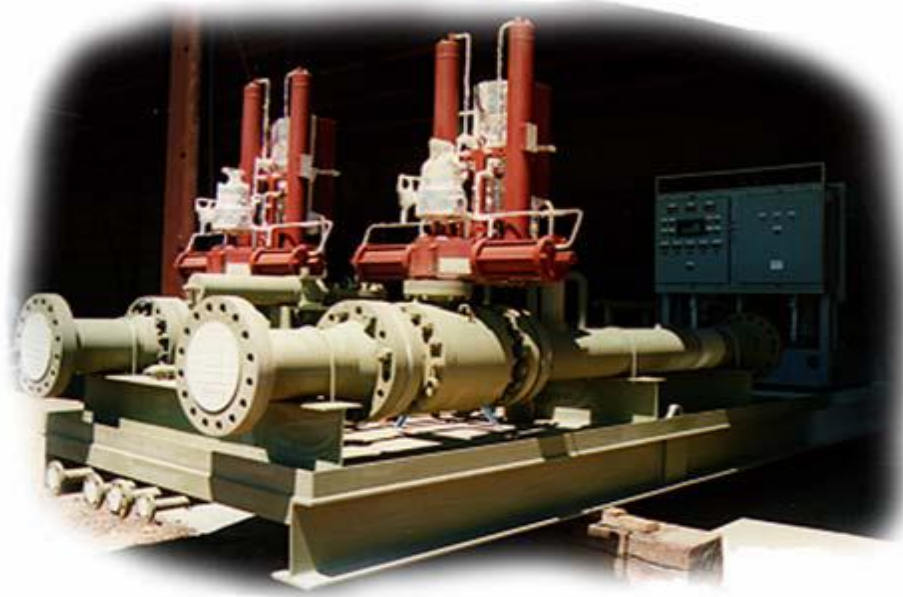

**MOUNTING PLATFORM AND SUPPORT STRUCTURES
SKID UNIT FOR WATER PURIFICATION
FABRICATION SHOP ASSEMBLY**



**CHEMICAL INJECTION SKID WITH 5,000 GALLON
STAINLESS STEEL TANK AND PUMP
DELIVERED AND INSTALLED**



16920 Kuykendahl
Suite 200
Houston, TX 77068
Main: 936.827.9944
www.AscenTrustLLC.com



The POWER of ENGINEERING

**APPENDIX C
ATTACHMENT D
ASCENTRUST, LLC.
COMPLETED CONSTRUCTION PROJECTS
IN MONTGOMERY COUNTY, TEXAS**

**FIRE STATIONS FOR LAKE CONROE FIRE DISTRICT
NEW CONSTRUCTION**



**NEW FIRE STATION ON HONEA EGYPT
LAKE CONROE FIRE DEPT STATION #33
REMODEL**



REMODEL OF LAKE CONROE FIRE DEPT STATION #32

**CONDOMINIUM PROJECTS ON LAKE CONROE
BUILDING ONE**



CONDOMINIUM PROJECT ON LAKE CONROE, BUILDING TWO



MEDICAL CLINIC IN WESTERN HILL PLAZA



**NURSING STATION
LAKE CONROE MEDICAL CLINIC**



**MEDICAL RECORDS AREA
LAKE CONROE MEDICAL CLINIC**



**WAITING ROOM
LAKE CONROE MEDICAL CLINIC**



INDUSTRIAL PROJECT IN MONTGOMERY, TEXAS



OFFICE BUILDING IN CONROE ON HIGHWAY 105



16920 Kuykendahl
Suite 200
Houston, TX 77068
Main: 936.827.9944
www.AscenTrustLLC.com

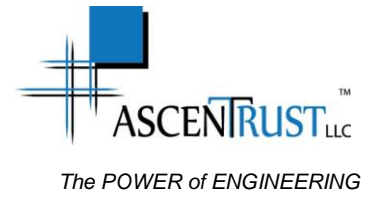

APPENDIX D
RESUME/PERSONAL PROFILE
FOR
JOSEPH DAVID CLEMENT FOURNIER

Resume

Joseph David Fournier

100 Hollow Tree Lane

Houston, Texas 77090

Phone: 936-827-9944

Email: joseph@ascenttrust.com

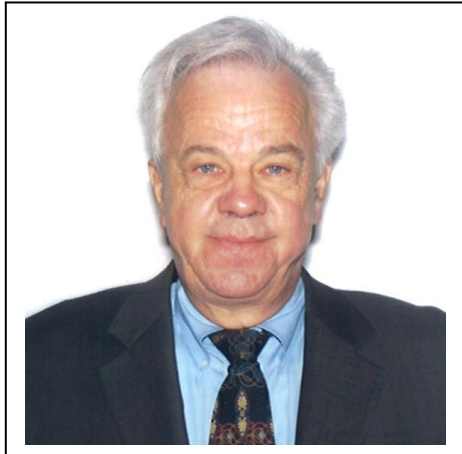

Mr. Joseph Fournier is an ENTJ personality on the Myers-Briggs, test by Consulting Psychologists Press, Inc., with an I.Q. of 160.

ENTJ

Frank, decisive, assumes leadership readily. Quickly sees illogical and inefficient procedures and policies, develop and implement comprehensive systems to solve organizational problems. Enjoys long-term planning and goal setting. Usually well-informed, well read, enjoy expanding their knowledge and passing it on to others. Forceful in presenting their ideas.

ENTJ Strengths

- **Genuinely interested in people's ideas and thoughts**
- **Enthusiastic and energetic**
- **Take their commitment very seriously**
- **Fair-Minded and interested in doing the Right Thing**
- **Very good with money**
- **Extremely direct and straightforward**
- **Verbally fluent**
- **Enhance and encourage knowledge and self-growth in all aspects of life**
- **Able to turn conflict situations into positive lessons**
- **Extremely high standards and expectations**
- **Able to dole out discipline**

Education

1965-1969

Bachelors of Science, Electrical Engineering, University of Alberta, Edmonton, Alberta Canada.
Awarded B.Sc.E.E. with distinction

1969-1972

Master of Science, Electrical Engineering, University of Alberta, Edmonton, Alberta Canada.
Thesis Topic-“Difference Frequency Harmonic Ion Heating in Magnetized Plasmas”

BACKGROUND SUMMARY

MANAGEMENT

Over 25 years of Progressive Upper Management experience in: Research and Development, Operations, Start-ups, Manufacturing, Engineering Design of all types of Energy production Facilities, Industrial, Commercial and Residential Construction, Software Development and real estate development which includes:

Business Planning and Development
Capital Acquisition
Asset Management
Marketing and Sales
Market and Sales Analysis
Financial Analysis
Financial Management
Human Resources Management
Operation Management
Time and Motion Analysis

Strategic Planning
Incorporation, Corporate Law
Capital Improvement
Purchasing
Marketing Management
Accounting
Business Law
Operation and Analysis
Multi-Site Management
Multi-Project Management

PROJECT MANAGEMENT

Over 30 years of Project Management Experience in diverse industries and multi-million dollar projects including, but not limited to:

- Power Plant Design and Construction
- Infrastructure: Water, Sewer, Fiber-Optic Cabling, Electrical Power Distribution
- Industrial, Commercial and Residential Construction Projects
- Nuclear Power Plant Development and Research (Patentable Research in fourth generation Nuclear Power Plant Design)
- Water Retention and flood control using water as a temporary levee system (Own part of this patent and working on extending the patent to absorb energy from the Tsunamis)
- Research and Development in Gas Turbine Technologies including closed cycle
- R&D in Superconducting Transmission Facilities
- Software Development (A/I Rules-based diagnostic medical Software of my own design and implementation)
- Software Development (Encryption Software)
- Telecommunication
- A/I Research

REGULATORY COMPLIANCE

E.E.O.C. Requirements	FCC
E.P.A.	A.D.A.
HIPAA	OSHA
NRC	TDEC

ENGINEERING

PROBLEM SOLVING & IMPROVING: The Senior Engineer comes from a high level Research and Development Background and has had remarkable success in diverse areas of Engineering. Not afraid to take on big challenges. Good grasp of technology and quickly able to extend existing technologies.

HIGHLY CREATIVE AND INNOVATIVE: always looking for ways to improve the technologies under my guidance in development. Develop practical solutions to problems. See the big picture, yet pay close attention to the details.

ELECTRICAL ENGINEERING

Mr. Fournier has over 40 years of electrical engineering experience in the field of commercial and industrial plant design, construction and plant start-up. Responsibilities include conceptual engineering detail design, short circuit studies, load flow studies, coordination studies for fuse, circuit breakers and relay setting, substation design, control schematic design, PLC design and programming in addition to project management and coordination, man power forecast, project scheduling, cost estimate and specification writing.

The following list indicates a few of the electrical engineering skill sets acquired by the Senior Engineer in his professional Career.

- Design of PCM equipment (First generation)
- Design of FM multiplexing equipment for T-1 lines
(First generation-Microwave repeater systems)
- Design of highly redundant systems for telemetry on oil-pipelines
- Design of a National Telephone System for the Country of Tunisia
- Design of large vertical electric motors- H.P. up to 5000hp.
- Design of high-voltage transmission facilities up to 144,000 Volts
3-phase Y and Delta Systems (underground and overhead)
- Design of underground and overhauled power feeds to minor subdivisions and shopping centers
- Load Analysis for residential, commercial and Industrial buildings
- Design of Natural gas turbine generation : up to 171MWe
- Design of Combined Cycle Power Plants, up to 650 MWe
- Design of Co-generation Power Plants: up to 100MWe
- Design of Natural gas steam turbine power plant: up to 650 MWe
- Load analysis for co-generation facilities

Civil Engineering

Over 30 years of experience in Civil Engineering Design and Implementation

Including:

- Project Design, Project Engineering and Permitting of subdivision maps in the State of California and State of Texas
- Design and Engineering of streets: curb and gutter, concrete and asphalted streets.
- Design of surface and underground drainage facilities for minor and major subdivisions.
- Design of flood control drainage in co-ordination with minor subdivision map
- Design of surface water detention facilities in Montgomery County, Texas
- Research and development for flood control system for the River Plantation flood District
- Research in water utilization in regards to flood control and retention of flood waters to recharge the aquifer. In Montgomery, Harris, Travis, Jefferson and
- Site Design for several Industrial, Commercial and Residential projects on Lake Conroe

Structural Engineering

- Design and construction of re-enforced concrete structures;
 1. monolithic cast-in-place
 2. pre-stressed and post tension tilt-wall and hollow core planks
- Design and build concrete foundations with drilled piers. Up to 50,000 Sq. ft.
- Design and build concrete foundation on concrete driven piles
- Design and build composite members: floor trusses and roof trusses both in wood and in steel.
- Design and build elevator shaft and two-hour partitions in commercial buildings.
- Design and build bulkheads and breakwaters.
- Design complex Levee Systems
- Design and Build wood-framed structures up to 4 stories
- Designing High-rise Structures: in steel and concrete

Catastrophic Loss Consulting

Over 30 years of experience in Catastrophic loss analysis including but not limited to:

- Hurricane damage assessment
- Stormwater damage assessment
- Earthquake damage assessment
- Fire damage assessment
- Easement and Right-of-Way Consulting

Computer Technology

Software Engineering, Programming and System Design

Over 30 years of Software and hardware System Engineering and programming beginning on mainframes and including minicomputers and microcomputer, and related technologies.

Designed and implemented algorithms in APL, P/L-1 and Fortran, on IBM 360 for the numerical solutions of partial Differential Equation. The primary partial Differential equation used was the Vlasov equation in ionized gas. This is the transport equation used for the non-linear interaction of lasers and plasma.

The numerical solutions were generated using harmonic analysis on the linearized solutions to Vlasov's equation. The solution to this problem was the major part of my thesis topic. The paper which was associated with this Master's Thesis was published in the Canadian Journal of Physics.

Difference frequency Harmonic Ionic Heating in Magnetized Plasmas.

Research studies, design, analysis and implementation of Artificial Intelligence algorithms based on;

- Sorting Algorithms
- Optimal Search Patterns
- Shortest Path
- Graphs (Nodes and edges defined with weights on the node and path)
- Multistage graphs with time domain multiplexing on weights ascribed to the nodes (for learning algorithms)
- All Pairs, Shortest Path
- Optimization of binary search trees
- Backtracking
- Branch-and-Bound

Extensive use of Fortran and ADA in developing software systems for General Telephone in their manufacturing facility at Lenkurt Electric, in Vancouver B.C.

Extensive use of Cobol and fortran in software systems in time and motion analysis for U.S. Motors

Since the fall of 1999 have been involved in the startup of a Software Development Company called **Advanced Software Development, Inc.** and a related marketing company called **Regional Electronic Medical Systems, Inc.**

The software package is a HIPAA compliant piece of medical software which is distributed, does data entry, data archival and medical billing.

- On this project I have done the major portion of the system specifications with the input from several of my doctor friends.
- -Project design was done using the UML Notation and use case analysis.
- -Project was first coded in Java
- -Project is now coded in C#.

Since October 2015 have been the lead Project Manager and coder for Interlok. We are re-developing an encryption software which was developed by a third party.

Language Proficiency

- Machine Languages (Instruction sets)
 - IBM 360/370/390 Instruction Set
 - Mips (Dec, Nintendo, Silicon Graphics, Sony)
 - RISC
 - ALPHA
 - Motorola 6800 Series Microprocessors
 - 80x86 Intel Microprocessors
- Coding in binary, octal, hexadecimal
- Coding in Assembler for mainframes and microcomputers

Programming languages mastered over the years

Fortran	Fortran IV
Fortran 90/95	Cobol
Apl	P/L-1
Lisp	Prolog
ML	
Ada	Pascal
C	C++
Java	C#
Javascript	Perl

Operating Systems

IBM Mainframes

OS 360/370/390
DOS
TSS 67
CP67 running MTS
MVS-TSO and a multitude of variants on mainframes, some Language specific

Digital Equipment

VAX

Unix and variants, language specific to C

DEC PDP 1, 8, 10, 11
AIX
Solaris
BSD-Unix
HP-UX
Linux: Fedora, CentOS, Ubuntu, Suse

P.C.-Systems

Dos and variants
OS/2 and variants
Mac and variants
Windows 3.1, Nt., 95,98, 2000, Mellenium, Xp.
Windows 8, 8.1 and Windows 10
Windows 2000 Advanced Server
Linux

Network Operating Systems

Novell Netware

Unix: NFS (Network File System)

Windows 2000 Advanced Server: LDAP

- LDAP (Lightweight Directory Access Protocol)

Linux

Networking

1. OSI Model

- Physical
- Data Link
- Network
- Transport
- Session
- Presentation
- Application

2. IEEE Networking Specifications

- 802.1 Internetworking
- 802.2 Logical Link Control
- 802.3 Ethernet LAN
- 802.4 Token Bus LAN
- 802.5 Token Ring LAN
- 802.6 Metropolitan Area Network (MAN)
- 802.8 Fiber Optic Technical Group
- 802.10 Network Security
- 802.14 Cable Broadband

3. Networking Protocols

- X-25
- TCP/IP
- IPX/SPX for old NetWare systems
- NETBIOS
- NETBEUI
- AppleTalk
- DNS
- WINS (Windows Internet Naming Service)

4. Transmission Media Characteristics

- Throughput
- Cost
- Size and Scalability
- Connectors
- Media Converters

5. Copper Cabling (There are thousands of different types of copper cables in use today on networks) Some of the most common types are;

- UTP Category 1 Signaling, door bells, alarm systems
- UTP Category 2 Digital Phone Systems, Apple LocalTalk

- UTP Category 3 10B-T, 4Mbps Token Ring
- UTP Category 4 16Mbps Token Ring
- UTP Category 5 100Base-Tx, 1000Base-T
- UTP Category 5e 100Base-Tx, 1000Base-T
- UTP Category 6* 100Base-Tx, 1000Base-T
- UTP Category 7* 100Base-Tx, 1000Base-T
- Backbone UTP Cable Analog and Digital voice Applications
- Shielded twisted-Pair (STP) 4Mbps and 16Mbps Token Ring
- Screened twisted-Pair 100Base-Tx, 1000Base-T
- Coaxial RG-8 Thick Ethernet(10Base-5), Video
- Coaxial RG-58 Thin Ethernet(10Base-2)
- Coaxial RG-59 CATV
- Coaxial RG-6U CATV, Satellite, HDTV, Cable Modems
- Coaxial RG-6U Quad Shield Same as RG6 with extra shielding
- Coaxial RG-62 ARCnet, Video, IBM 3270

6. Optical Fiber

A. SONET (Synchronous Optical Network)

- OC1 51.840Mbps
- OC3 155.520Mbps
- OC9 466.560Mbps
- OC12 622.080Mbps
- OC18 933.120Mbps
- OC24 1244.160Mbps
- OC36 1866.240Mbps
- OC48 2488.32Mbps
- OC96 4976.640Mbps
- OC192 9953.280Mbps

B. FDDI (Fiber Distributed Data Interface)

- Old (MAN) fiber technology speed at 100Mbps.
- Essentially a “Stretched” version of Token Ring LAN technology.

C. Ethernet (GBE) Gigabit Ethernet and (10GBE) 10 Gigabit Ethernet

- 1000Base-SX

D. Asynchronous Transfer Mode

- Unchannalized data transfer methodology useful on Sonet rings
- Designed to provide bandwidth on demand

E. Fiber Channel

- Developed interconnect technologies with **FDDI** and **ESCON**

F. Synchronization of SONET and Ethernet

- Working on the design for a synchronous transfer of Data between SONET and Ethernet over Optical Fiber

Mathematics Background:

35 years of Advanced Study and research @ graduate math level in such diverse mathematical disciplines as;

- Logic
- Sets and Classes
- Functions, Relations and Partitions
- Cardinal Numbers
- Groups
 1. Semi-groups/ Monoids
 2. Normal Groups/ Quotient groups/ Homomorphisms
 3. Symetric/ Altenative/ dihedral groups
 4. Categories, products, Co-Products, generators
- Group Structures
 1. Free Abelian Groups
 2. Finitely Generated Abelian Groups
 3. Non-Abelian Groups (Important in the physics of Quantum Fields)
 4. Nilpotent and Solvable Groups (Important in theoretical Physics)
 5. Lie Groups (Underpinning for all of Modern Physical Representations)
- Rings
 1. Homeomorphisms
 2. Ideals
 3. Factorization of Commutative Rings
 4. Rings of Quotients
 5. Polynomial Rings
 6. Factorization of Polynomial Rings
- Modules
 1. Homeomorphisms and exact sequences
 2. Free modules and vector spaces (Important in Quantum Mechanics)
 3. Tensor Products (Important in general Relativity)
 4. Modules over Principal Ideal Domains
 5. Algebras
- Fields and Galois Theory
 1. Galois Groups of Polynomials
- Structure of Fields
 1. Lineal Disjointness
 2. Seperability
- Linear Algebra
 1. Matrices and Maps
 2. Determinants
 3. Decomposition of Linear Transformations
 4. Affine Maps
 5. Characteristic Polynomials
 6. Eigenvalues and Eigenvectors
- Topology
- Algebraic Topology
- Differential Topology
- Differential Geometry
- Lie-Groups and their related Lie Algebras

- Fiber Bundles and Fiber Spaces

The mathematical requirements for the study of encryption are easily satisfied by a series of reviews which I have undertaken as of October 1, 2015.

Quantum Physics Background

35 years of Advanced Study and research @ graduate level physics in such diverse disciplines as;

1. Underpinnings of Quantum Mechanics

- Non-Commuting Variables
- Wave-Particle Duality
- The Nature of Quantum Reality, The holistic nature of a Wave-function
- The mysterious “Quantum Jump” and the collapse of complex entangled Wave-functions to eigenstates
- Probability Distribution in a wave-function
- Position states/Momentum states
- Energy States/Time states

2. Quantum Algebra, geometry, spin

- The difference between **U** and **R**
- The linearity of **U** and the difficulties with Resolvants.
- Unitary structures, Hilbert Spaces and Dirac Notation
- Unitary Evolution;
 1. Schrödinger Picture
 2. Heisenberg Picture
- Quantum Observables
- Yes/No operators/Projections
- Null measurements; helicity
- Spin and spinors
- The Reiman sphere of a two-state system
- Higher Spin; Majorana picture
- Spherical Harmonics
- Relativistic Quantum Angular Momentum
- General isolated Quantum objects
- Bosons and fermions
- Quantum States of Bosons and Fermions

3. The Entanglement Problem in Quantum Mechanics

- Quantum Mechanics of many particle systems
- Hugeness of many particle state space
- Quantum Entanglement: Bell’s inequality
- EPR (Einstein-Padolski and Rosen) Paradox
- Bohm-Type EPR Experiments
- Hardy’s EPR
- Mysteries of Quantum Entanglement
 1. Entanglement Spread
 2. Intervention of “Conscious Observer”
- The measurement Paradox

4. The Conventional Ontology of Quantum Mechanics

“ The formalism of Quantum Mechanics tells us essentially nothing about the actual Quantum Reality of the world, but merely allows us to compute probabilities for alternative realities which might occur.”

5. Unconventional Ontologies for Quantum Theory

- A.** Copenhagen
- B.** Many World Interpretation
- C.** Environmental Decoherence
- D.** Consistant Histories
- E.** Pilot Waves
- F.** New Theory with Objective R
- G. Fournier theory of Spiritual Interaction**

This is the basis of my research in Consciousness and Quantum Field Theory.

6. Solid State Physics

- A.** Quantum Theory of Metal
- B.** Quantum Theory of Semiconductors
- C.** Quantum Electronics
- D.** Superconductivity (Theoretical) Type I and II superconductors
- E.** High Temperature Superconductivity

Nuclear Engineering Background

1. Foundational Material

- History of Nuclear Energy
- Nuclear Fission/ Nuclear Reactors
- Multiplication factors and Nuclear Criticality
- Interaction of Neutrons with Matter
- Cross-Section for Neutron Reactions
 - A.** Elastic
 - B.** Inelastic
 - C.** Capture
- Rates of Neutron Reactions
- The Fission Process
 - 1.** Fission Cross-Section
 - 2.** Fission Rates and Reactor Power
 - 3.** Fission Products
 - 4.** Radioactivity of Fission Fragments
- Neutron Capture

2. Reactor Theory

- A.** The Diffusion of Neutrons
 - Diffusion Theory
 - Solution of Diffusion equation in two and three dimensions for plane geometry, cylindrical geometry and spherical geometry. The pebbles in the pebble-bed reactor are spherical and the solution to the diffusion equation has to be cast in Legendre Polynomials and Bessel Functions.
 - Boundary Conditions

- B. The Monoenergetic Neutron Transport Theory**
 - The slowing down of neutrons
 - Scattering/ elastic/ non-elastic/capture
 - Spatial Distribution of Thermal Neutrons
 - Neutron Lifetime in finite reactors
 - Relections in Reactors

- 3. Nuclear Reactor Core Design**
 - Determination of core criticality and Power Distribution
 - Reactivity and Core Analysis
 - Depletion Analysis

- 4. Mathematical Modeling (Computer Code)**
 - Cross-Section Library Processing Codes
 - ENDF/B files
 - Differential scattering cross sections generated as a sequence of Legendre Polynomials.
 - For Resonance Regime use of NR and NRIM approximations
 - Multi-group constant Generation Codes
 - For Light Water Reactors (LWR) use MUFT-GAM type calculations
 - For Fast Spectrum Reactors use SOFICATE or TEMPEST calculations for thermal neutrons
 - For High Temperature Gas Reactors (HTGR) Include GAM or MICROX for fast group constants and GATHER for thermal group constants.
 - Static Design Code: Used to obtain a global spatial dependence of the neutron flux throughout the reactor core.
 - Use of Transport Codes: ANISN and TWOTRAN
 - Time Dependent Design Codes
 - Depletion Code
 - Fuel Cycle Analysis
 - Reactor Kinetics Analysis
 - Mechanical Analysis of Reactor Code
 - Gas Dynamics of Reactor Core
 - Numerical Analysis in Legendre Polynomials
 - Gas Flow over spherical surfaces in B.C.C. and F.C.C. placement of pebbles

- 5. Material Damage in Reactor Core**
 - Radiation damage to Silicon Carbide Cladding for Pebble Bed Modular Reactor.
 - Radiation Effects
 - Fuel Creep and Swelling
 - Fission Gas Release
 - Pore Migration
 - Deterioration of Mechanical Properties of Cladding

- 6. Economic Analysis of Nuclear Energy**

- 7. Safety and Regulatory Considerations**

Technical Papers

1. Difference Frequency Harmonic ion Heating in magnetized Plasma (Published)
2. Consciousness and Quantum Field Theory (An ongoing research project)
3. Nuclear Energy: An Introduction
4. Pebble Bed Modular Reactor: An Introduction
5. NRC Pre-Application Summary: A white Paper
6. Siting: A study in the Requirements for a Nuclear Power Plant
7. Nuclear Power and the Environment: An Honest Appraisal
8. Non-Relativistic Quantum Mechanics (Intermediate Level Unpublished Notes)
9. Non-Relativistic Quantum Mechanics (Intermediate Level Unpublished Notes) Part 2
10. Non-Relativistic Quantum Mechanics (Intermediate Level Unpublished Notes) Part3
11. Introduction to Quantum Mechanics (Advanced Level Unpublished notes)
12. Notes on Relativistic Quantum Mechanics
13. Notes on Quantum Field Theory (Non-Relativistic)
14. Notes on Gauge Field Theory
15. Notes on Gauge Field Theory (Part Two, Scalar field theory)
16. Notes on Gauge Field Theory (Part Three, Quantum Chromodynamics)
17. The Higgs Mechanism (Notes on Quantum Field Theory)
18. Path Integral Methods in Quantum Field Theory
19. Spinor Field Theory (The Quantum Field Theory of Fermions)
20. Basic Mathematical Ideas (Intermediate Level)
21. Notes on the theory of Superconductivity
22. Superconductivity and Gauge Field Theory
23. Complex Variables and Complex Analysis (Advanced Level Introduction)
24. Notes on Calculus and Advanced Calculus (Part One)
25. Notes on Calculus and Advanced Calculus (Part Two)
26. Notes on Differential Geometry
27. Notes on Group Theory
28. Notes on Newton' Laws
29. Introduction to Electromagnetic Theory
30. Introduction to General Relativity
31. Mathematics of Green's Functions
32. Introduction to manifolds
33. Introduction to Complex Manifolds
34. Introduction to Algebraic Topology
35. Compactness and Topology
36. Lie Groups and Lie Algebras in Differential Geometry
37. Notes on Fibre Bundles (Intermediate)
38. Fibre Bundles, An Advanced Introduction
39. Differential Geometry, An Introduction
40. Notes on Differential Forms
41. Manifolds and Riemannian Geometry in General Relativity
42. Legacy Systems- A White Paper
43. TCP/IP- A white Paper
44. ESCON- A White Paper
45. Fibre Channel- A White Paper
46. Sonnet- A Technical Introduction
47. Ethernet- A White Paper

- 48.** UML (Unified Modeling Language) An Introduction
- 49.** Java- An Introduction
- 50.** XML – An Introduction
- 51.** Eclipse- An Introduction
- 52.** IBM-390- An Introduction
- 53.** Unix- A White Paper
- 54.** Linux- An Introduction
- 55.** Red Hat Clustering- An introduction

Joseph D. Fournier

16920 Kuykendahl
Woodlands Texas 77380
Suite 200
Cell Phone (936) 827-9944

Experience

- 2009-Present** **AscenTrust, LLC. President and Senior Engineer**
AscenTrust, LLC. consists of network of Senior Engineers and Scientists providing Project Management capabilities to Governments in third world Countries. The Senior Engineer is providing services to Nigeria, Ghana, Cameroon, Ivory Coast, Vietnam and the Philippines.
- 2012-Present** **Nitex International, LLC. Managing Member and Senior Research Scientist and Engineer**
Nitex Provides Logistics and Supply Chain Management for several Nigerian Companies located in Port Harcourt, River State, Nigeria.
- 1997-Present** **Advanced Software Development, Inc. President and Senior Research Scientist**
Ongoing software development in the medical field. Also involved in A/I rule-based querying methodologies for DB2 and MySQL in conjunction with MSQL and Oracle. The Intelligence layer as to be used for Data Mining.
Presently involved in the development of encryption software for the Windows, Linux, Apple, iPhone and Android Systems.
- 2001-Present** **Regional Electronic Medical Systems, Inc. President**
Regional Electronic Medical Systems, Inc. provides a sophisticated implementation of a Medical EMR. Based on the .NET framework of Microsoft. Have finished developing a prototype. Prototype is ready for Alpha testing in a Medical Clinic.
- 1995-Present** **Nuclear Technologies, Inc. President and Senior Research Scientist and Engineer**
Research and development of a proprietary design for a Pebble Bed, Modular Nuclear Power Plant.
- 2009-Present** **NuEnergy, Inc. President and Senior Engineer**
Incorporated as a Utility Company in the State of Texas, to interact with Texas Public Utility Commission, Entergy Texas and ERCOT in obtaining authorization to license and Construct Natural Gas fired Power Plants.

1997-2008

Land and Sea Enterprises, Inc. President and Senior Engineer

Land and Sea Enterprises is a General Building Contracting firm providing sophisticated solutions to problems in Design, Engineering, and Construction. Land and Sea Enterprises, Inc. has broad experience in Industrial, Commercial and Residential construction.

In the Lake Conroe area of Houston is a \$25,000,000.00, 114 unit condominium and marina project **Sunset Shores Condominiums**. Responsible for Project Design, Project Engineering and Project Management and some on-site Construction Management for this project. (Three year project)

Involved in the design phase is a \$18,000,000.00, high rise, 102 unit condominium project in Conroe Texas. This condo project is a senior living project located next to the Conroe Senior Center (Friendship Center) and Conroe Park. The project is called **Villas of LaRadiance**. Responsible for Project Design, Project Engineering and Project Management and some on-site Construction Management for this project. (18 Months project)

In the design, planning, financing and permitting phases we presently have an additional \$300,000,00.00 or more in condominium and Independent Living High-Rise projects (in concrete and steel), The largest of these project is a multi-year project to re-furbish the Del-Lago Hotel and turn it into a senior center and assisted, nursing home project. This project is called **The Commodore on Lake Conroe**. We are working with a Non-Profit funding agency to obtain a grant to do this project.

We were also partnering with several local non-profit organizations to develop a prototype for a two story Assisted Living Project, which can be extended to include a nursing home and a medical clinics on site. These low-rise projects will be wood-framed. The first of these projects will be built in Tomball Texas and is scheduled to break ground in January of 2008. The completed value of this project is approximately \$20,000,000.00.

Commercial projects include Project Design, Project Engineering and Project Management for a Fire Station for Lake Conroe Fire Department, to be located on Honea Egypt in Montgomery County. Design and build commercial strip center. Design of a R.V. park and design and build a carwash. Design, permit and build three medical Clinics and a dental lab in Spring Texas. Many remodeling projects, including but not limited to concrete paving, framing, roofing sheetrock repair, painting and specialized cabinet work. Major projects are a 12,000 sq. ft. 2-story office

building on highway 105 west with an estimated cost of construction at near \$1,300,000.00.

Experienced in all types of construction: Wood-framed , steel-framed and concrete commercial from single story to a ten stories condominiums and office buildings.

Engineering and Consulting on storm-water issues. Expert witness in Coastal Engineering and Storm-water surges in South Texas and Cameron Parish Louisiana. Involved in South Texas in the creation of a Go-Zone for the Hurricane Recovery.

Consulting on catastrophic casualty,

1997-Present

Construction Technologies, Inc. President and Senior Research Engineer

Ongoing water retention research project involving a patented technology. Flo-Barrier uses water to retain water. The scope of the research project has been increased to include the possibilities of using the tubes in a concrete-reinforced bed, sitting on top of an existing levee. This levee system will reinforce the levee and increase its height in times of flooding.

1987-1997

Owner, Alpha Omega Construction

Commercial and residential construction in Dallas, Texas until 1994. Moved to April Sound in the Lake Conroe area in 1994. In Dallas- Several high grade commercial projects in the World Trade Center. Many high grade commercial and residential projects for architects and interior designers. The biggest project was a 10,000 sq. ft. house for architect and his client. Various reconstruction jobs including a 4000 sq. ft. reconstruction of a burned house. Annual gross to \$500,000-\$1,000,000 - Moved to April Sound in 1994-

Commercial and residential construction in the Lake Conroe area including a Manufacturing facility in Montgomery, Texas for Spirit Industries owned by Mr. Gerald Foss.

1984-1987

Project Manager, Project Engineer, Estimator: Amtex Construction Dallas, Texas

Responsible for in house Project Design, Project Engineering, Project Management and estimating all major construction projects for Amtex Construction. Amtex had an annual gross of \$5,000,000.00-8,000,000.00 Also responsible for on site co-ordination of men and material.. Also acted as the on site construction co-ordinator. Responsible for the successful completion of all the construction projects, on the construction side.

Large construction projects, in co-ordination with Tempo-Mechanical-The largest Mechanical contractor in Dallas. Co-ordinator and bidder of all Government, Hud-type projects.

1976-1984

Project Manager, Project Engineer-Land and Sea Ent., Inc. In 1984 I was doing in excess of \$50,000,000.00 of bidding yearly. General Building contractor- B-1 license holder.

Largest project approximately 100 unit apartment project. All classes of commercial and residential construction projects. Land development projects- lot splits and minor subdivisions. (less than 15 lots)

Large amount of Hud work for the San Diego Housing Authority. Developed expertise in Casualty losses due to earthquakes. Also developed into an expert witness for the analysis and repair of structural defects. This work was done in co-ordination with an authorized Civil Engineering firm and was always done in association with an insurance company in relation to the stipulations of a lawsuit. Expert witness on lawsuits connected to structural defects with expertise in mitigation of consequences of structural defects.

1974-1976

Assistant to the Vertical Product Manager for U. S. Motors-a Division of Emerson Electric. Prescott Arizona

Worked in the U.S. Motor vertical motor manufacturing plant in Prescott Arizona. Essentially ran the vertical product dept. while my boss was busy becoming a vice President of Emerson Electric.

In charge of client relationship with representatives of large pump manufactures who buy huge quantities of vertical electric motors. Worked with these large accounts to facilitate and expedite motor manufacturing and delivery.

Wrote technical manual for all vertical motors from 5 h.p. to 5000 h.p. (the biggest motor which we manufactured at the time). Ran the Gant charting for the manufacturing facility Estimating time and material for production control. Many marketing-type activities and many Industrial Engineering type of activity associated with problem in production control at the plant. The computer routing the on-time delivery system, which was being implemented, was in the Emerson building on the East coast and the manufacturing facility was in the west.

1972-1974

Senior System Engineer for Lenkurt Electric, a Division of General Telephone Vancouver B.C. Canada

Lenkurt Electric is the manufacturing arm of GTE. I was attached to the Engineering design group for system development.

The biggest system I worked on was the phone system for Tunisia. Total cost approximately \$25,000,000.00. Design and implementation of multiplexing equipment- Amplitude modulation-frequency modulation and pulse code modulation. Considerable design experience in frequency domain multiplexing and time-domain multiplexing. Time domain multiplexing via the use of T1 and T3 is now the common form of data transmission along twisted pair and optical fiber.

Responsible for the design and the preliminary implementation of a new microwave backbone telephone system for the country of Tunisia. Given the design and implementation of the Tunisia system because of fluency in the French language.

Designed microwave bearer equipment and systems for telephone and television carriers before the advent of satellites. I was also responsible for a design upgrade of the Aramco pipeline telemetry system in Saudi-Arabia for the Saudis

16920 Kuykendahl
Suite 200
Houston, TX 77068
Main: 936.827.9944
www.AscenTrustLLC.com



APPENDIX E
PASSPORT PHOTO
FOR
JOSEPH DAVID CLEMENT FOURNIER

16920 Kuykendahl
Suite 200
Houston, TX 77068
Main: 936.827.9944
www.AscenTrustLLC.com



The POWER of ENGINEERING

APPENDIX F
SHORT BIO
FOR
ANGELA MOORE

BIO
MS ANGELA MOORE



Angela Moore has been in the financial world 1993 ranging from the residential market to the commercial market. She has purchased and sold commodities since 2002.

She has funded projects ranging from energy projects: solar energy, wind energy, water energy; casino financing, business expansion, angel investment and micro funding financing.

She has owned a general contracting firm, mortgage brokerage and a business financial consulting firm.

Angela has been on the Board of Directors of **AscenTrust, LLC.** since 2013. She is also taking an active role in the Corporation as its Vice President. MS. Moore is involved in many of the financial transactions required to fund the **FEED** (Front-end Engineering and Design) which is our main source of business.